



# SunMaxx™

Information Guide: Solar Radiant Space Heating



P: 877.SUNMAXX / 888.SOLAR.11  
[www.siliconsolar.com](http://www.siliconsolar.com) / [www.sunmaxxsolar.com](http://www.sunmaxxsolar.com)

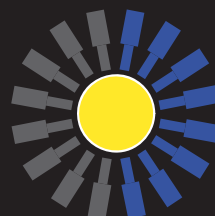

**Silicon Solar Inc**  
Innovative Solar Solutions

# SunMaxx™

## Information Guide: Solar Radiant Space Heating



Radiant floor space heating is one of the most common applications for solar thermal systems. Most traditional heating sources come from oil, natural gas, propane or electricity, all of which emit fossil fuels and have some of the most volatile prices of any commodity. Heating cost increases are raising the cost of living and doing business, beyond many people's means.

Space heating accounts for nearly 30 - 40 percent of average annual energy bills. The figures are roughly the same for businesses. By cutting 50 - 60%, or more, of heating fuel use, home and business owners can save hundreds, if not thousands, of dollars every year.

A SunMaxx solar heating system can be used to augment most modern heating systems, including:

- In-floor radiant systems
- Baseboard radiator systems
- For hot air systems

These three types of heating systems are the most common types in use in the United States today, meaning that a SunMaxx solar heating system is applicable for most homes and business. There are numerous other heating systems that can be used with a solar thermal system, so ask your local SunMaxx dealer if your system can be integrated. Additionally, a new heating system can easily combine any optimal heating system and a SunMaxx solar thermal system.

A pre-packaged solar heating system can be purchased to offset a pre-determined number of BTUs, from your space heating system, regardless of its total BTU load. These pre-packaged systems are extremely affordable, and can be installed without complex system design or engineering.

However, for a more accurate sizing, or for a applications that are not covered by a pre-packaged system, contact a SunMaxx representative. They will help you calculate the BTU load of the space you are heating, and size a solar thermal system that meets the solar fraction you desire within your budget.

# Radiant Heating Basics

## Radiant In-Floor Heating

Radiant In-floor heating systems are among the most cost-effective and efficient types of heating systems available today, especially with the integration of a SunMaxx solar heating system. The two types of radiant In-floor heating systems are:

### 1. Thermal mass

A thermal mass system uses a large mass, such as concrete floor, to store heat that will be radiated slowly into the surrounding room as it is needed. This is one of the most cost-effective heating systems available.

PEX tubing is laid within a concrete floor as it is poured. When heated HTF is fed through the PEX tubing, the heat is transferred to the surrounding mass. As the temperature in the room with the thermal mass floor drops, heat is radiated out, stabilizing the temperature automatically.

A thermal mass system can use a solar or traditional heating system, or a combination of both, as the heat source.

### 2. Wooden sub-floor

The second type of radiant In-floor heating system uses PEX tubing looped under the subfloor of a hardwood or tile floor. As heated HTF is cycled through the PEX loops, the heat is transferred through the floor to room(s) above.

Wooden sub-floor Systems are great for using radiant in-floor heating systems in multiple floor homes and apartment buildings.

Unlike a thermal mass system, a radiant heating system under a wooden or tile floor must include a solar hot water storage tank for thermal storage.

Because of the low temperatures required for radiant heating with a thermal mass or sub-floor heating system, a larger solar hot water storage tank may be used. This increases the overall efficiency of the system by providing additional thermal storage for a larger volume of BTUs than would be possible in other system types.

Radiant in-floor solar heating systems are the most efficient solar heating system type, and are more cost-effective than other system types.

## Baseboard Radiator Heating

Baseboard radiators are extremely common in older homes, as well as many offices, hotels and apartment buildings in the United States. The relative affordability of installing these systems make them extremely popular, as well as cost-effective.

The only disadvantage of using a solar heating system with baseboard radiators is that this type of system requires higher temperatures than others. This means that a smaller solar hot Water storage tank should be used, lowering the overall efficiency of the solar heating system.

However, with the proper balance of solar collectors and solar hot water storage tank, integrating a solar heating system with a baseboard radiator heating system is an affordable, efficient and cost-effective use of solar heating, and can save home and business owners hundreds, if not thousands, of dollars a year in heating costs.

## Forced Hot Air Heating

Whether utilizing oil, propane, natural gas or electricity as its fuel source, forced hot air systems are extremely popular and common in homes, as well as commercial and municipal locations.

By using an air to water heat exchanger (see the product brochure for more information) the HTF within the solar heating system can be used to heat the air within your furnace. The heat exchanger goes into the plenum of the furnace, as the HTF travels through the exchanger, the air within the furnace is heated.

The use of a solar heating system for forced hot air will dramatically reduce the amount of heating fuel you use to heat your home or business, saving you hundreds, or thousands, of dollars in heating costs.

# Typical System Components & Layouts

## Radiant In-Floor System - Thermal Mass

- Solar collectors - typically evacuated tube collectors
- Solar storage tank - with internal heat exchangers
  - 1 (or more) for solar loop input
  - 1 (or more) for radiant zone output
  - 1 (or more) to tie in domestic hot water heating
- Or, thermal mass - concrete floor
- PEX tubing (rated for 180 °F, or above)
- Controller (for solar loop control)
- Zone controllers / thermostats
- Solar hot water circulator pumps
  - Circulator(s) for solar collector loop
  - Circulator(s) for radiant heating zones
- Assorted plumbing hardware to complete installation

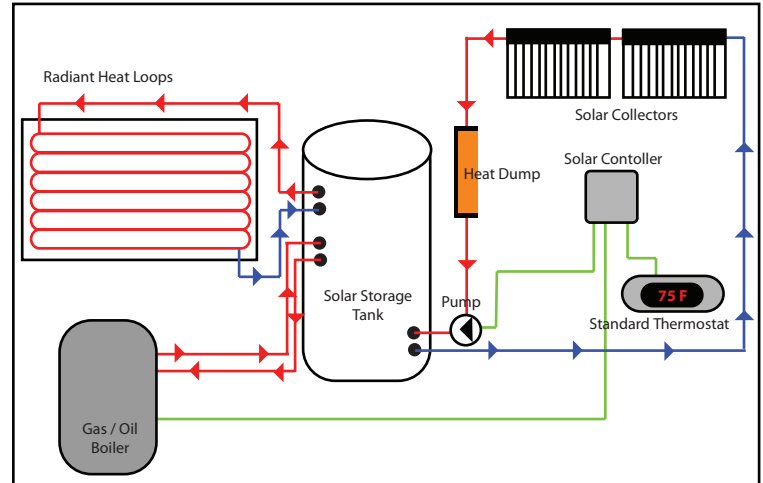

## Baseboard Radiator System

- Solar collectors - typically evacuated tube collectors
- Solar storage tank - with internal heat exchangers
  - 1 (or more) for solar loop input
  - 1 (or more) for radiant zone output
  - 1 (or more) to tie in domestic hot water heating
- PEX tubing (rated for 180 °F, or above)
- Controller (for solar loop control)
- Zone controllers / thermostats
- Solar hot water circulator pumps
  - Circulator(s) for solar collector loop
  - Circulator(s) for radiant heating zones
- Assorted plumbing hardware to complete installation

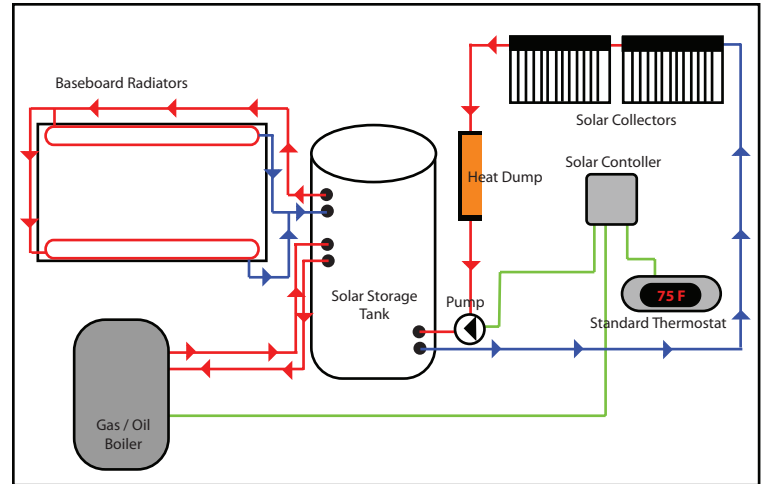

## Forced Hot Air System

- Solar collectors - typically evacuated tube collectors
- Solar storage tank - with internal heat exchangers
  - 1 (or more) for solar loop input
  - 1 (or more) for radiant zone output
  - 1 (or more) to tie in domestic hot water heating
- PEX tubing (rated for 180 °F, or above)
- Controller (for solar loop control)
- Zone controllers / thermostats
- Solar hot water circulator pumps
  - Circulator(s) for solar collector loop
  - Circulator(s) for radiant heating zones
- Assorted plumbing hardware to complete installation

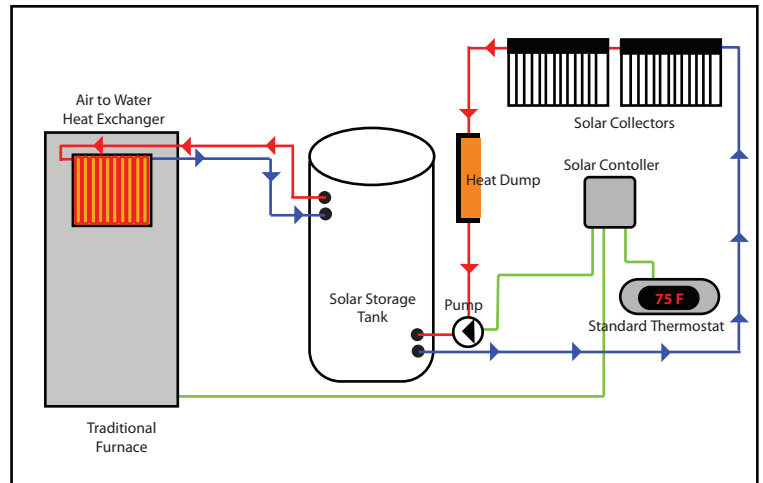

# Sizing a SunMaxx Solar Heating System

## Calculating Your BTU Load

The first step in sizing a SunMaxx solar heating system for your home, or other building, is to calculate the BTU load of the space. There are two ways to go about this.

### 1. Using your known BTU load

Know the BTU load from previous heating seasons. You can easily determine the number of BTUs you use to heat your home, or other building, by knowing the amount of fuel you use for heating during one, or more, heating seasons.

With the amount of fuel you use, you can calculate the total number of BTUs you need to supply.

### BTU supplied by traditional heating sources

Heating Fuel	BTU/Unit
Heating Oil	139,000 / Gallon
Propane	92,000 / Gallon
Natural Gas	100,000 / Therm
Electricity	3,400 / kWh

By using your fuel usage over the course of a heating season and calculating the number of BTUs you use, you can determine the number of SunMaxx solar collectors your solar heating system should contain.

The math involves taking the number of BTUs used during a heating season, and dividing this by the typical BTU production of a SunMaxx solar collector in your area during the heating season. This will give you the number of solar collectors that will account for the BTUs used in heating your home or office.

The RETScreen software used, and offered, by Silicon Solar is a great tool in making these calculations based on performance specifically at your location.

### 2. Calculating heat loss

Another effective method for sizing a SunMaxx solar heating system is calculating the heat loss of your home or office. To calculate heat loss, you must factor in the insulation for all areas of your home, or office, that are to be heated, included factoring in all of the walls, ceilings, windows, doors, etc.

Sizing your SunMaxx solar heating system to offset the heat loss of your home or office will go a long way towards lowering your overall heating bills and making your Sunmaxx solar heating system as cost-effective and affordable as possible.

## Why You Should use Evacuated Tubes

Though either SunMaxx evacuated tube or flat plate solar collectors can be used in a SunMaxx solar heating system, Silicon Solar recommends that you use evacuated tube solar collectors.

Because heating systems are most common in areas with moderately to extremely cold weather during the heating season, SunMaxx evacuated tube solar collectors are the preferred solar collectors for a solar heating system.

SunMaxx evacuated tube solar collectors are more efficient and reliable in extremely cold climates, suffering from far-less heat loss than flat plate solar collectors. This extended performance is key to a SunMaxx solar heating system that is affordable, efficient and cost-effective.

## Additional Information & Resources

If you would like additional information on SunMaxx solar heating systems, or system components, you should refer to:

- SunMaxx product brochures for the components
- Your SunMaxx Sales Representative, Technician, Dealer or Installer
- Online resources:
  - [www.siliconsolar.com](http://www.siliconsolar.com)
  - [www.sunmaxxsolar.com](http://www.sunmaxxsolar.com)
  - [solarhotwater.siliconsolar.com](http://solarhotwater.siliconsolar.com)

2917 State Hwy 7, Bainbridge, NY 13733

P: 888.765.2711 (Integrated Products)

P: 877.786.6299 (Solar Thermal)

[www.siliconsolar.com](http://www.siliconsolar.com) | [www.sunmaxxsolar.com](http://www.sunmaxxsolar.com)

© 2008 Silicon Solar Inc - All Rights Reserved | shw-gib-004

*In order to maintain the highest standards of service and knowledge of the latest solar technologies, Silicon Solar is a proud member of:*

