



StorMaxx SE Series Tanks





SunMaxx Solar
Bainbridge, NY 13733
P: 1.877.786.6299
F: 1.800.786.0329
www.sunmaxxsolar.com

Explanation of warning labels

 Take note of all symbols and notations intended to draw attention to potential hazards or important product information.

 WARNING
Indicates an imminently hazardous situation which, if not avoided, could result in death, serious injury or substantial product/property damage.

 IMPORTANT INFORMATION
Indicates important information and special advices which present no risk to people or property

 CAUTION
Indicates an imminently hazardous situation which, if not avoided, may result in minor injury or product/property damage.

 ELECTRIC SHOCK HAZARD
Indicates an imminently hazardous situation which, if not avoided, may result in death, serious injury or substantial product/property damage.

 SCALD RISK
Indicates the risk of serious scald injuries due to very high water temperatures which may result in death.
Un-tempered hot water can cause severe burns instantly resulting in severe injury or death
Children, elderly and the physically or mentally disabled are at highest risk for scald injury.
Always feel water before bathing and showering.
Use temperature limiting valves to reduce water temperature at faucets.

Introduction	Explanation of Warning labels 2
	Table of Content 3
General Safety Information	Important Regulatory and Installation Requirements 4
General Information	About these Instructions 5
	Product Information..... 6
Installation	Locating the Water Heater..... 7
	Minimum Clearances..... 8
	Insulation Mounting 8
Connections	Water Connections 9
	TPR Valve 9
	Other Connections 10
	→ Connection Diagram 18
Electric Heating Element	Electrical Connection 11
	Installation 12
	Connection Diagram..... 13
	Temperature Settings 14
	Element Replacement..... 14
Additional Information	General Operation 15
	Maintenance..... 16
	Repair and Service..... 17
	Connection Diagram 18

General Safety Information

The warranty on this water heater/storage unit is in effect only when the water heater/storage unit is installed and operated in accordance with local codes and these instructions. The manufacturer of this water heater/storage unit will not be liable for any damage resulting from failure to comply with these instructions. Read these instructions thoroughly before starting.

WARNING

Improper installation, adjustment, alteration, service or maintenance can cause serious injury or property damage. Refer to this manual. For assistance or additional information, consult a qualified installer or service agency.

WARNING

The recommended temperature for normal residential use is 120 °F (49 °C). The dial on the thermostat does not always reflect the out coming water temperature, which could occasionally exceed 120 °F (49°C). The variation in out coming temperature could be based on factors including but not limited to usage patterns and type of installation. Test your water at the tap nearest to the water heater.

WARNING

Hotter water increases the risk of scald injury. Before adjusting the water temperature setting, read this instruction manual. Temperatures at which injury occurs vary with the person's age and the length of exposure. The slower reaction time of children, elderly, and physically or mentally challenged persons increases the scalding hazard to them. It is recommended that lower water temperatures be used where these exposure hazards exist. Such households may require a temperature setting less than 120 °F (49 °C) to prevent accidental contact with hot water.

WARNING

Water heater blankets are not recommended and will void the warranty.

This manual has been prepared to acquaint you with the installation, operation and maintenance of your water heater and to provide important safety information.

ATTENTION

When using electrical appliances, basic safety precautions to reduce the risk of fire, electric shock or injury to persons should be followed, including:

1. **READ ALL INSTRUCTIONS BEFORE USING THIS WATER HEATER.**
2. This water heater must be grounded, when electric elements are used. Connect only to properly grounded outlet.
3. Install or locate this water heater only in accordance with the provided installation instructions.
4. Use this water heater only for its intended use as described in this manual.
5. Do not use an extension cord set with this water heater. If no receptacle is available adjacent to the water heater, contact a qualified electrician to have one properly installed.
6. As with any appliance, close supervision is necessary when used by children.
7. Do not operate this water heater if it has been damaged or dropped.
8. This water heater should be serviced only by qualified service personnel. Contact nearest authorized service facility for examination, repair or adjustment.

GENERAL INFORMATION

This water heater/storage unit must be installed in accordance with local codes. In the absence of local codes, install this water heater/storage unit in accordance with the N.E.C. Reference Book (latest edition).

The warranty for this water heater/storage unit is in effect only when the water heater/storage unit is installed, adjusted, and operated in accordance with these Installation and Operating Instructions. The manufacturer will not be held liable for damage resulting from alteration and/or failure to comply with these instructions.

This water heater/storage unit may be used independently when equipped with a heating element or as a storage unit when used in conjunction with an existing water heater or boiler.

This water heater/storage unit has been designed and certified for the purpose of heating potable water. The installation and use of this water heater/storage unit for any purpose other than the heating of potable water may cause damage to the water heater/storage unit and create a hazardous condition and nullify the warranty.

WARNING

Incorrect operation of this appliance may create a hazard to life and property and will nullify the warranty.

Do not use this appliance if any part has been submerged in water. The plumbing professional responsible for the installation of this water heater/storage unit should be contacted to inspect the appliance and to replace and part of the control system, including thermostat (if equipped), which has been submerged in water.

For water heaters equipped with a heating element; make sure that the rating plate on the water heater is referenced for certainty that the correct voltage is being supplied to the water heater.

WARNING/DANGER

Do not store or use gasoline or other flammable, combustible, or corrosive vapors and liquids in the vicinity of this or any other appliance.

A sacrificial anode is used to extend tank life. The removal of this anode, for any reason, will nullify the warranty.

In areas where water is unusually active, and / or may occur at the hot water faucet due to a reaction between the sacrificial anode and impurities in the water. If this should happen, an alternative anode may be purchased from the supplier that installed this water heater/storage unit. This alternative anode will minimize the odor while protecting the tank. Additionally, the water heater/storage unit should be flushed with appropriate dissolvers to eliminate any bacteria.

IMPORTANT

Before proceeding, please inspect the water heater/storage unit and its components for possible damage. DO NOT install any damaged components. If damage is evident, please contact the supplier where the water heater/storage unit was purchased or the manufacturer listed on the rating plate for replacement parts.

Water Treatment / Filtration

In areas where poor water conditions are suspected (i.e. lime, iron and other minerals), it is essential that the water be tested and appropriate action taken to prevent damage to the indirect heater and ensure the quality of the water.

Temperature control

The proper temperature setting for domestic hot water use is 120 °F (49 °C). If hotter water is required a tempering device or anti-scald device must be installed at the domestic hot water outlet of the heater or at the point of use. Table 1 details the approximate relationship of water temperature and the time with regard to scald injury. It is important for the user to understand the necessity of tempering or anti-scald devices when using hotter water in domestic water heating systems.



SCALD RISK

Hot water in excess of 120 °F (49 °C) can cause scalding!

A tempering valve or anti-scald valve shall be installed and used according to the manufacturer's directions to prevent scalding. Many state and local codes now require installation of these devices. The tempering valve or anti-scald valve will ensure potable water temperatures at the desired set point with a higher degree of accuracy.

General Information

The following chart details the relationship between water temperature and time for scalding injury to occur.

approx. Water temperature	Time to produce 2nd and 3rd Degree burns on adult skin
120 °F (49,0	more than 5 minutes
125 °F (51,5	1.5 to 2 minutes
130 °F (54,5	about 30 seconds
135 °F (57,0	about 10 seconds
140 °F (60,0	less than 5 seconds
145 °F (63,0	less than 3 seconds
150 °F (63,5	about 1.5 seconds
155 °F (68,5	about 1 second

Anode rods (only applicable to enameled tanks)

The anode rod is used as a sacrificial element within the volume of the storage tank. The purpose of the magnesium anode rod is to protect the inside of the tank against corrosion. The anode rod should be inspected twice in the first year and at least yearly once a time interval for inspection has been developed. Water conditions can influence the consumption rate of the anode rod. Please see the maintenance section of this manual for instructions on how to change the anode rod in your water heater.

CAUTION

Hydrogen gas is produced in a hot water system served by the heater that has not been used for a long period of time (2 weeks or more). Hydrogen gas is extremely flammable. To reduce the risk of injury under these conditions, it is recommended that the hot water faucet be opened for several minutes at the kitchen sink before using any electrical appliance connected to the hot water system. When hydrogen is present, there will probably be an unusual sound such as air escaping through the pipe as the water begins to flow. There should be no smoking or open flame near the faucet at the time it is open.

Temperature and pressure relief valve (TPR Valve)

CAUTION

To reduce the risk of excessive pressures and temperatures in this water heater, install temperature and pressure protective equipment required by local codes and no less than a combination temperature and pressure relief valve certified by a nationally recognized testing laboratory that maintains periodic inspection of production of listed equipment or materials, as meeting the requirements for Relief Valves and Automatic Gas Shutoff Devices for Hot Water Supply Systems, ANSI Z21.22. This valve must be marked with a maximum set pressure not to exceed the marked maximum working pressure of the water heater. Install the valve in an opening provided and marked for this purpose in the water heater, and orient it or provide tubing so that any discharge from the valve exits only within 6 inches above, or at any distance below, the structural floor, and does not contact any live electrical part. The discharge opening must not be blocked or reduced in size under any circumstances.

Backflow Preventer (closed loop system)

Some local municipal codes and ordinances require the use of these devices on potable (domestic) water lines. Where backflow preventers are required, it will be necessary to install a thermal expansion tank (designed for used with potable water) in order to prevent pressure build up in the indirect heater and associated piping, which could cause the T&P valve to discharge. Follow the expansion tank manufacturer's recommendations when selecting a tank for your hot water system.

Product information

50USG (200 ltr), 79 USG (300 ltr) and 119 USG (450 ltr) capacity Enameled indirect-fired domestic hot water storage tank with no, one or two heat exchanger coils.

INSTALLATION

Locating the water heater/storage tank

If you have a choice of where to install the water heater consider the following:

- 1 Put the water heater indoors as close as possible to where the most hot water is needed, to prevent heat loss through water pipes.
- 2 It is handy to have a floor drain, tub or sink nearby, which will make it easier to drain water from the water heater. It is also a good place to end the drain line of the Temperature Pressure Relief Valve (TPR Valve)
- 3 The solar water heater or the pipes and the connections may, in time, leak. Put the water heater/storage tank in a place where a water leak will not damage anything.
- 4 You must not put the water heater in an area where it might freeze.

Make sure that you are able to reach the drain valve and all access panels when water heater is in place. This will make it easy to service the water heater.



WARNING

Water heater/storage units are heat producing appliances. To avoid damage or injury, there shall be no materials stored against the water heater/storage unit and proper care shall be taken to avoid unnecessary contact (especially by children) with the water heater/storage unit. UNDER NO CIRCUMSTANCES SHALL FLAMMABLE MATERIALS, SUCH AS GASOLINE OR PAINT THINNER BE USED OR STORED IN THE VICINITY OF THIS WATER HEATER/STORAGE UNIT OR ANY LOCATION FROM WHICH FUMES COULD REACH THE WATER HEATER/STORAGE UNIT.

This water heater **MUST** be installed indoors out of the wind and weather.

This water heater/storage unit shall **NOT** be installed in any location where gasoline or flammable vapors are likely to be present,

To comply with NSF requirements this water heater is to be:

- Sealed to the floor with sealant, in a smooth and easily cleanable way, or
- Installed with an optional leg kit that includes legs and/or extensions that provide a minimum clearance of 6" beneath the water heater.

The location where this water heater/storage unit is to be installed is of utmost importance. Before installing this water heater/storage unit, consult the installation section of these instructions. After reading these Installation and Operating instructions, select a location for the water heater/storage unit where the floor is level and is easily accessible to a power supply and water connections. It is recommended that the water heater/storage unit be located near the center of greatest hot water usage to prevent heat loss through the pipes.

DO NOT locate the water heater/storage unit where water lines could be subjected to freezing temperatures. Locate the water heater/storage unit so that access panels and drain valves are accessible.

Water heater/storage unit corrosion and component failure can be caused by the heating and breakdown of airborne chemical vapors. Examples of some typical compounds that are potentially corrosive are: spray can propellants, cleaning solvents, refrigerator and air conditioning refrigerants, swimming pool chemicals, calcium and sodium chloride (salts), waxes and process chemicals. These materials are corrosive at very low concentration levels with little or no odor to reveal their presence.

NOTE: DAMAGE TO THE WATER HEATER/STORAGE UNIT CAUSED BY EXPOSURE TO CORROSIVE VAPORS IS NOT COVERED BY THE WARRANTY. DO NOT OPERATE THE WATER HEATER/STORAGE UNIT IF EXPOSURE HAS OR WILL OCCUR. DO NOT STORE ANY POTENTIALLY CORROSIVE COMPOUNDS IN THE VICINITY OF THE WATER HEATER /STORAGE UNIT.

This water heater/storage unit must be located in an area where leakage of the tank or water line connections and the combination temperature and pressure relief valve will not result in damage to the area adjacent to the water heater/ storage unit or to lower floors of the structure. When such locations cannot be avoided, a suitable drain pan must be installed under the water heater/storage unit. The drain pan must have a minimum length and width of at least 4 in. (10.2 cm) greater than the diameter of the water heater. The drain pan, as described above, can be purchased from your plumbing professional. The drain pan must be piped to an adequate drain. The piping must be pitched for proper drainage.

Note: For California installation this water heater must be braced, anchored, or strapped to avoid falling or moving during an earthquake. See instructions for correct installation procedures. Instructions may be obtained from California Office of the State Architect, 400 P Street, Sacramento, CA 95814.

Installation

CAUTION

DO NOT store or use gasoline or other flammable, combustible or corrosive vapors and/or liquids in the vicinity of the water heater or any other appliance.

IF YOU SMELL GAS:

DO NOT try to light any appliance.

DO NOT touch any electric switch; do not use any telephone in your building.

Immediately call your gas supplier from a telephone in another building. Follow your gas supplier's instructions.

If you cannot reach your gas supplier, call the fire department.

DO NOT OPERATE THE APPLIANCE UNTIL THE LEAKAGE IS CORRECTED!

CAUTION

Do not drop water heater or lay heater down on its side. Move the water heater into position by sliding or using an appropriately sized hand truck.

The solar indirect water heater must be installed indoors. Locate the water heater as close as practical to the solar heating system and leave sufficient clearances for servicing the heater. The entire solar heating system should be located as close as possible to points of hot water use for the fastest delivery of hot water.

If possible, please use the following installation clearances for service access.

Storage Capacity	USG ltr	79 300	119 450
Rear	inches mm	18 460	18 460
Sides	inches mm	12 300	12 300
Top	inches mm	48 1200	48 1200
Front	inches mm	24 600	24 600

Insulation mounting

SYNTHETIC MATERIALS ARE SUBJECT TO TEMPERATURE VARIATION!!

Do not put the insulation on the tank if temperature is below 68 °F (20 °C). Cold stored insulations need to warm up to room temperature!

CAUTION

Never use any heat source to speed up the process of bringing the insulation back to room temperature, as this could damage the insulation and could cause harmful fumes and/or fire.

After setting up the storage tank and before connecting the drinking water-, circulation- and heating lines, the insulation has to be put on.

IMPORTANT

For the position of the flange perforation Ø 7 inches (180 mm), please take a look on the enclosed drawing. Please do not use tools or band clamps! Please don't try to close the insulation by force!

To mount put the insulation loosely around the storage tank. Adjust the insulation by tapping with the palm of the hand from the backside in direction to the zipper till the insulation can be closed easily

The closing direction of the zipper is always FROM THE TOP TO THE BOTTOM!

Water Connections

NOTE: Before proceeding with the installation, close the main water supply valve.

After shutting the main water supply valve, open a faucet to relieve the water line pressure to prevent any water from leaking out of the pipes while making the water connections to the water heater/storage unit. After the pressure has been relieved, close the faucet. Make the proper plumbing connections between the water heater/storage unit and the plumbing system in the house. Install a shut-off valve in the cold water supply line.

CAUTION

If sweat fittings are to be used, DO NOT apply heat to the nipples of the water heater/storage unit. Sweat the tubing to the adapter before fitting the adapter to the water connections. It is imperative that heat is not applied to the nipples containing a plastic liner.

If this water heater/storage unit is installed in a closed water supply system, such as the one having a back-flow preventer in the cold water supply, provisions shall be made to control thermal expansion. DO NOT operate this water heater/storage unit in a closed system without provisions for controlling thermal expansion. Your water supplier or local plumbing inspector should be contacted on how to control this situation.

After installation of the water lines, open the main water supply valve and fill the water heater/storage unit. While the water heater/storage unit is filling, open several hot water faucets to allow air to escape from the water system. When a steady stream of water flows through the faucets, close them and check all water connections for possible leaks.

NEVER OPERATE THE WATER HEATER/STORAGE UNIT WITHOUT FIRST BEING CERTAIN IT IS FILLED WITH WATER.

Temperature and Pressure Relieve Valve (TPR)

For protection against excessive temperatures and pressure, install temperature and pressure protective equipment required by local codes, but not less than a combination temperature and pressure relief valve certified by a nationally recognized testing laboratory that maintains periodic inspection of production of listed equipment or materials, as meeting the Requirements for Relief Valves and Automatic Gas Shutoff Devices for Hot Water Supply Systems, ANSI Z21.22, and the Standard CAN1-4.4 Temperature, Pressure, Temperature and Pressure Relief Valves and Vacuum Relief Valves.

The combination temperature and pressure relief valve shall be marked with a maximum set pressure, not to exceed the maximum working pressure of the water heater/storage unit. The combination temperature and pressure relief valve shall also have an hourly rated temperature steam BTU discharge capacity not less than the hourly input rating of the water heater/storage unit.

Install the combination temperature and pressure relief valve into the opening

Note: Some models may already be equipped or supplied with a combination temperature and pressure relief valve. Verify that the combination temperature and pressure relief valve complies with local codes. If the combination temperature and pressure relief valve does not comply with local codes, replace it with one that does. Follow the installation instructions above on this page.

Install a discharge line so that water discharged from the combination temperature and pressure relief valve will exit within 6 inches above or any distance below the structural floor and cannot contact any live electrical part. The discharge line is to be installed to allow for complete drainage of both the temperature and pressure relief valve and the discharge line. The discharge opening must not be subjected to blockage or freezing.

DO NOT thread, plug or cap the discharge line. It is recommended that a minimum of 4 inches (10.2 cm) be provided on the side of the water heater/storage unit for servicing and maintenance of the combination temperature and pressure relief valve.

DO NOT place a valve between the combination temperature and pressure relief valve and the tank.

WARNING

Hydrogen gas can be produced in a hot water system served by this water heater/storage unit that has not been used for a long period of time (generally two weeks or more). Hydrogen gas is extremely flammable.

To reduce the risk of injury under these conditions, it is recommended that the hot water faucet be opened for several minutes at the kitchen sink before using any electrical appliance connected to the hot water system. If hydrogen is present, there will probably be an unusual sound such as air escaping through the pipe as the water begins to flow. There should be no smoking or open flame near the faucet at the time it is open.



SCALD RISK

Under certain conditions, water in this water heater/storage unit may become excessively hot. It is recommended that an ASSE approved mixing valve may be installed in the outlet line to reduce the risk of scald injury by preventing point of discharge water temperatures in excess of 140 °F (60 °C).

FOR INSTALLATION SEE CONNECTION DIAGRAM (P. 18)

DO NOT install a check valve or any other device that would prevent the reverse flow of water unless required by local codes. A closed system will result and frequent operation of the relief valve will occur.

After the installation of all water lines is complete, open the main water supply valve and fill the water heater/storage unit. Open several hot water faucets to allow air to escape from the system while the water heater/storage unit is filling. When water passes through all the faucets, close the faucets and check for possible leaks in the system.

This water heater/storage unit can deliver scalding temperature water at any faucet in the system. Be careful whenever using hot water to avoid scalding injury. Certain appliances such as dishwashers and automatic clothes washers may require increased temperature water. By setting the thermostat on this water heater/storage unit to obtain increased temperature water required by these appliances, you may create the potential for scald injury. To protect against injury, you should install an ASSE approved mixing valve in the water system.

This valve will reduce point of discharge temperature by mixing cold and hot water in branch supply lines. Such lines are available from the local plumbing supplier. Please consult with a plumbing professional.

- The tank including the parts mounted at the manufacturer's premises shall be subjected to the tightness test (not the pressure test) of the overall system. In rare cases, screw connections can become loose as a result of transport, shocks, handling mistakes, etc. and shall, therefore, be included in the check performed during commissioning.
- The fastening torque of the flanges shall be between 20 N and 30 N. As the seal may have set, the fastening torques shall be tested before filling the system. Following each start-up (after the first heating), the fastening torques shall be checked and the flanges retightened, if necessary. Seals are wear parts and intended for single use only; in the case of revision or back fitting, but after 2 years at the latest, the seals shall be replaced.
- With combination storage systems the potable water side shall always be filled and commissioned first. The working pressures given on the type plate shall not be exceeded. Water hammers in the potable water network shall be avoided by suitable measures (expansion vessel, delayed closing fittings, etc.). In the case of special steel corrugated tubes, an expansion vessel is obligatory.
- Any bare-tube heat exchangers installed shall be operated using water only (no steam). For heating medium temperatures exceeding 203 °F (95 °C) the following applies: The insulation shall be protected against temperatures above 203 °F (95 °C) (points of contact with the heat exchanger connections). Appropriate connecting and sealing materials shall be used.
- A suitable water filter shall be installed in the cold water feed line and commissioned accordingly, taking into account the current state of the art.
- Clean the outside of the device using water only (moist cloth).
- We retain the right for changes of the technical data and comments due to further development.

Electrical Connections/Heating Element

This section applies to water heaters equipped with a heating element.

Before any electrical connections are made, be sure that the water heater is full of water and that the valve in the cold water supply line is open. Check the rating plate and wiring diagram before proceeding. Thermostats are factory set and wired in accordance with the wiring diagram. The dealer in your area ordered this water heater wired at the factory to comply with existing area codes, but local utility codes may require or allow other circuitry. Consult your local power company to determine the correct electrical hook-up in order to meet local utility and building codes and in order to obtain the most economical rates. Also check to find out if you are required to obtain a permit before starting the installation. The maximum wattage and rated voltage are shown on the water heater data plate. The water heater must be well grounded.

A green ground screw is provided at the electrical connection point for connecting a ground wire.

WARNING

Confirm that all electrical connections are unpowered before installing or servicing electrical components / connections within the water heater.

WARNING

The water heater must be electrically grounded in accordance with local codes or, in the absence of local codes, with NFPA 70. Failure to properly wire electrical connections may result in serious physical harm. Electrical power may be from more than one source. Make sure all power is off before attempting any electrical work.

Installation Information Heating Element

Screw-in heaters are standard horizontal positioned. Other installation positions are just allowed after consultation with the producer. Only SW46 tools shall be used to mount the heating element. The turning moment must not exceed 25 Nm.

ATTENTION

Screw-in heaters must be installed by an authorized specialist. The tank must be connected durably and reliable with the ground wire connection.

WIRING OF ELEMENT

Determine voltage and wattage from the rating plate attached to the solar water heater. All external wiring, connection, and over current protective devices must be provided and installed in accordance with the latest edition of the National Electrical Code, local codes, and local utility requirements. The solar water heater must be electrically “grounded” by the installer. A green ground screw has been provided on the solar water heater’s junction box.

IMPORTANT

Connect the screw head with ground wire connection.

The grounding electrode conductor shall be of copper, aluminum, or copper clad aluminum. The material shall be resistant to corrosion, and shall be of one continuous length without a splice or joint. Rigid metal conduit, intermediate metal conduit, or electrical metallic tubing may be used for the grounding means if conduit or tubing is terminated in fittings approved for grounding.

Flexible metal conduit or flexible metallic tubing shall be permitted for grounding if all the following conditions are met:

- The length in any ground return path does not exceed 6 feet.
- The circuit conductors contained therein are protected by over current devices rated at 20 amperes or less.
- The conduit or tubing is terminated in fittings approved for grounding.

WARNING

Never use this water heater /storage unit unless it is completely filled with water

Electric Heating Element

WARNING

SOLAR WATER HEATERS EQUIPPED FOR ONE TYPE VOLTAGE ONLY.

This solar water heater is equipped for one type of voltage only. Check the rating plate near the bottom access panel for the correct voltage.

Do not use this solar water heater with any voltage other than the voltage shown on the model rating plate.



ELECTRIC SHOCK HAZARD

Failure to use the correct voltage can cause problems which can result in DEATH, SERIOUS BODILY INJURY OR PROPERTY DAMAGE. If you have any questions or doubts consult your electric company.

CAUTION

If wiring from the fuse box or circuit breaker box was aluminum for the old tank, replace it with copper wire. If you wish to reuse the existing aluminum wire, have the connection at the solar water heater made by a competent electrician. Contact your local utility to arrange for a professional electrician.

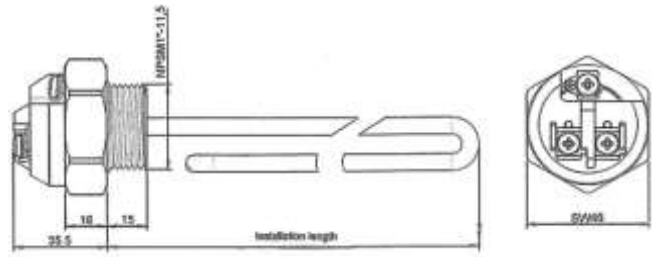

Installation length 17.33 inches (460mm)

Power 4.50 kW

Installing the Heating Element

- 1 Make sure the tank is drained before starting to install the heating element.
- 2 Take off the access panel and fold away the insulation.
- 3 Pull the bracket over the heating element and screw the heating element into the 1" NPSM connection.

ATTENTION

The turning moment **MUST NOT** exceed 25 Nm.

- 4 Wire the element and the thermostat as shown above.
 - Adjust the thermostat to the right temperature.

Connection Diagram

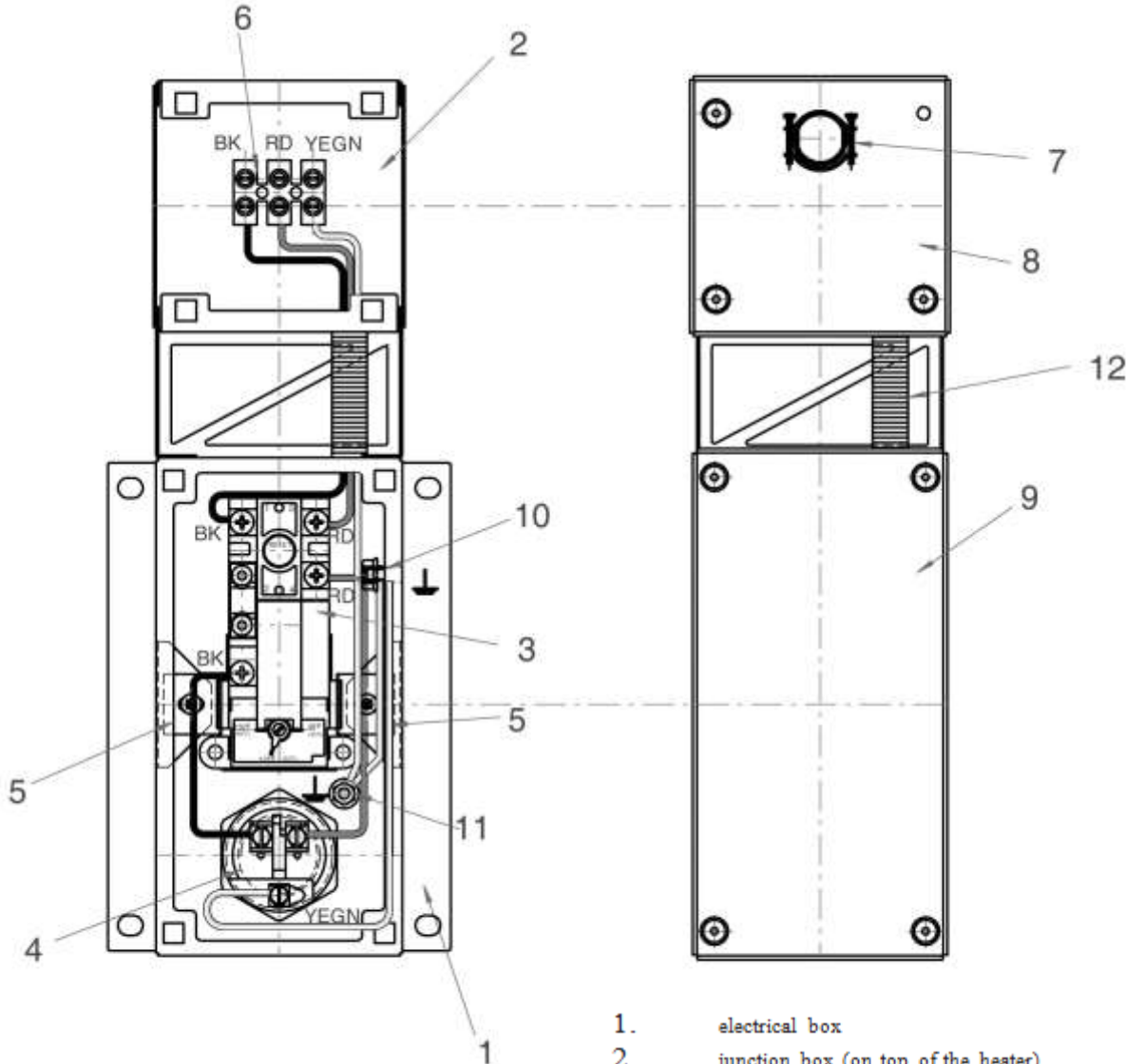

Color: Green
 Color: Red
 Color: Black

} Ground Wire
} To Power Supply

1. electrical box
2. junction box (on top of the heater)
3. controller / limiter
4. electrical element
5. retainer clip
6. Insulating Screw Joint
7. Strain Relief clamp top cover junction box
8. top cover electrical box
9. plastic cover
10. ground bolt M5
11. ground bolt M5
12. cable tube

Electric Heating Element

Temperature Settings

To adjust the temperature settings:

- 1 Turn “off” the electrical power at the junction box of the water heater.



ELECTRIC SHOCK HAZARD

Failure to turn “off” electrical power to the solar water heater will result in the possibility of **DEATH, SERIOUS INJURY OR PROPERTY DAMAGE.**

- 2 Take off the access panel and fold away the insulation.
- 3 Turn the water temperature dial clockwise to increase the temperature, or counterclockwise to decrease the temperature.
- 4 Fold the insulation back in place and replace the access panel.
- 5 Turn “on” the power supply.

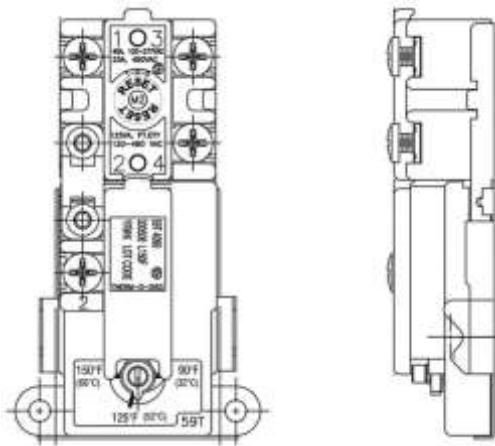

approx. Water temperature	Time to produce 2nd and 3rd Degree burns on adult skin
120 °F (49,0	more than 5 minutes
125 °F (51,5	1.5 to 2 minutes
130 °F (54,5	about 30 seconds
135 °F (57,0	about 10 seconds
140 °F (60,0	less than 5 seconds
150 °F (63,5	about 1.5 seconds
160 °F (71,0	about 0.5 seconds
170 °F (76,5	Nearly instantaneous

Each thermostat is factory preset at 120 °F (49 °C) to reduce the risk of scald injury. This setting has proven by the experience to be most satisfactory from the standpoint of operation costs and household needs.

Solar water heaters installed in Florida require the thermostat to be set at 125 °F (52 °C).

Element Replacement



WARNING

Replacement elements must be the same voltage and no greater wattage than listed on the model rating plate affixed to the solar water heater.

- 1 Turn “off” the electrical supply to the water heater.



ELECTRIC SHOCK HAZARD

Failure to turn “off” electrical power to the solar water heater will result in the possibility of **DEATH, SERIOUS INJURY OR PROPERTY DAMAGE.**

- 2 Drain the solar water heaters by following the directions for draining in your water heater installation manual.
- 3 Take off the access panel and fold away the insulation.
- 4 Replace the old element and the gasket. You should always use a new gasket when you replace the element.
- 5 Install new element like described under “install the heating element”.
- 6 Fold the insulation back in place and close the access panel by properly screwing the lid back into place.



CAUTION

For your safety **DO NOT** attempt to repair thermostat, heating element or electrical wiring (if applicable). Always refer such repairs to a qualified

GENERAL OPERATION

Before closing the switch to allow electric current (if applicable) to flow to the water heater, make certain that the water heater is full of water and that the cold water inlet valve is open. Complete failure of the heating element (if applicable) will result if they are not totally immersed in water at all times.

When the switch is closed, the operation of this solar electric water heater is automatic. The thermostat (if applicable) are preset to the "HOT" setting to provide a water temperature of approximately 120°F (49°C) to reduce the risk of scald injury.

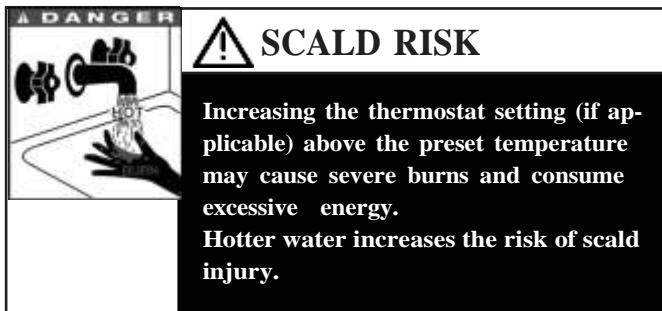

Care must be taken whenever using hot water to avoid scalding injury. Certain appliances require high temperature hot water (such as dishwashers and automatic clothes washers).

TO FILL THE WATER HEATER/STORAGE UNIT:

- 1 Close the water heater drain valve by turning the knob clockwise.
- 2 Open the cold water supply shut-off valve.
 - Open several hot water faucets to allow air to escape from the system.
- 4 When a steady stream of water flows from the faucets, the water heater is filled. Close the faucets and check for water leaks at the water heater drain valve, combination temperature and pressure relief valve and the hot and cold water connections.

To drain the water heater/storage unit:

Should it become necessary to completely drain the water heater/ storage unit make sure you follow the steps below:

- 1 Disconnect the power supply to the water heater (if applicable). Consult the plumber or electric company in your area for service.
- 2 Close the cold water supply shut-off valve.
 - Open the drain valve on the water heater/storage unit by turning the knob counter-clockwise. The drain valve has threads on the end that will allow connection of a standard hose coupling.
- 4 Open a hot water faucet to allow air to enter the system.

To refill the water heater/storage unit, refer to "TO FILL THE WATER HEATER/STORAGE UNIT".

Additional Information

MAINTENANCE

CAUTION

The water heater/storage unit should be inspected at a minimum of annually by a qualified service technician for damaged components. **DO NOT** operate this water heater/storage unit if any part is found damaged.

CAUTION

Shut off the electric power (if applicable) whenever the water supply is turned off.

Shut off the electric power (if applicable) and water supply, and drain the heater completely to prevent freezing whenever the building is left unoccupied during the cold weather months.

The following maintenance should be performed by a qualified service technician at the minimum periodic intervals suggested.

In some installations, the maintenance interval may be more frequent depending on the amount of use and the operating conditions of the water heater/storage unit. Regular inspection and maintenance of the water heater/storage unit will help to insure safe and reliable operation.

- 1 Annually check the operation of the thermostat (if applicable).
- 2 Bi-annually check the seal around the heating element for leaks (if applicable). If there is any sign of leaking, disconnect the power supply to the water heater and contact the plumbing professional that installed this water heater or a qualified service technician.
- 3 At least once a year, check the combination temperature and pressure relief valve to insure that the valve has not become encrusted with lime. Lift the lever at the top of the valve several times until the valve seats properly without leaking and operates freely.
- 4 If the combination temperature and pressure relief valve on the appliance discharges periodically, this may be due to thermal expansion in a closed water supply system. Contact the water supplier or local plumbing inspector on how to correct this situation. Do not plug the combination temperature and pressure relief valve outlet.

5. Monthly drain off a gallon of water from the water heater/storage unit to remove silt and sediment.



SCALD RISK

This water may be hot.

6. A combination sacrificial anode rod has been installed to extend tank life (only applicable to enameled tanks). The anode rod should be inspected periodically and replaced when necessary to prolong tank life. Water conditions in your area will influence the time interval for inspection and replacement of the anode rod. Contact the plumbing professional who installed the water heater/storage unit or the manufacturer listed on the rating plate for anode replacement information.

Anode rod (only applicable to enameled tanks)

The anode rod should be inspected twice in the first year of operation and at least yearly once a time interval for inspection has been developed. It is recommended to check the rod six months after the heater is installed. If the anode rod had reduced in size by two-thirds of its original diameter or shows signs of pitting, it is time for replacement. Take the following steps when changing the anode rod:

- 1 Shut off water supply
 - Open any faucet to relieve tank pressure
- 2 Remove caps on water heater top; push insulation aside.
- 4 Remove rod and replace with new rod.
 - Turn water supply back on and leave faucet open until air is out of line.
- 6 Turn faucet off and check that new rod doesn't leak.
 - Snap caps back into place.

Contact your supplier or plumbing professional for replacement parts or contact the company at the address displayed on the rating plate of the water heater/storage unit. For faster and better service, please provide the part name, model, and serial number(s) of the water heater(s)/storage unit(s) when ordering parts.

Manufacturers Plate

Repair and Service Parts List

The following parts may be ordered through the store or dealer from whom you purchased the solar water heater, or direct from the factory listed on the model & rating plate located on the lower front of the solar water. Selling prices will be furnished on request or parts will be shipped at prevailing prices and you will be billed accordingly.

When ordering repair parts always give the following information: (1) Part description, (2) Model serial number, (3) Element wattage, (4) Voltage, (5) Part number.

Solar water heater

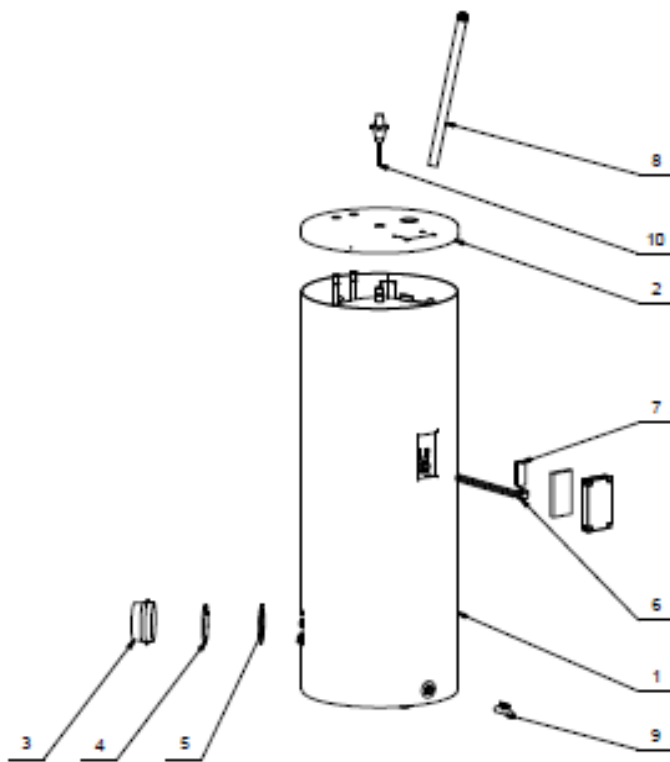

1	OUTER CASING
2	SHELL LID, PLASTIC
3	FLANGE COVER
4	FLANGE LID - BLIND PLUG
5	PACKING RING
6	HEATING ELEMENT
7	THERMAL FUSE
8	ANODE

